

MSE

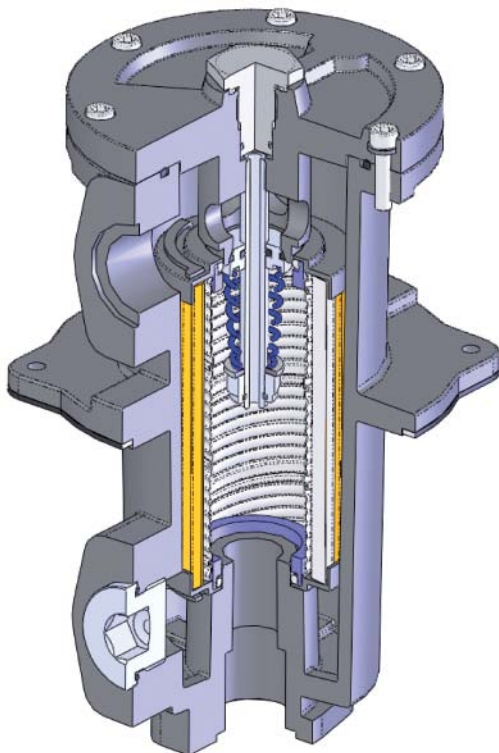

SUCTION FILTER

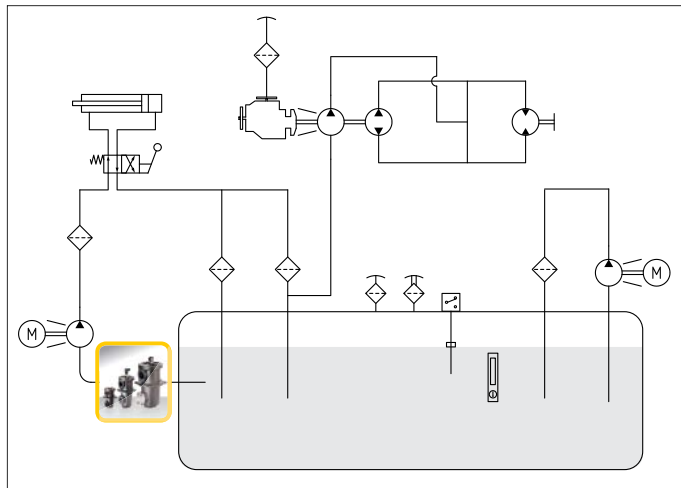



MSE

Port sizes: 1/2" ÷ 3"

Flow rates: 3 ÷ 1.200 l/min

TECHNICAL DATA

Max. working pressure: 2 MPa (20 bar)

Max. test pressure: 3 MPa (30 bar)

Bursting pressure: 6 MPa (60 bar)

Fatigue test: 0 ÷ 1,5 MPa (15 bar) / 1.000.000 cycles

Bypass valve: return Δp 300 kPa (3 bar) $\pm 10\%$

suction Δp 30 kPa (0,3 bar) $\pm 10\%$

Filter element collapse pressure:

standard: Δp 1 MPa (10 bar)

Working temperature: -25 ÷ +110°C

MATERIALS

Head and bowl: anodized aluminium
steel for MSE250

Bowl type 250: anodized steel

Seals: standard NBR
on request FKM

COMPATIBILITY (ISO 2943:1999)

Full with fluids: HH-HL-HM-HV-HTG
(according to ISO 6743/4).

For fluids different than the above mentioned,
please contact our Sales Department.

All tests performed according
to the following standards:

ISO 2941: Element collapse resistance test

ISO 2942: Production integrity test

ISO 2943: Fluids compatibility

ISO 3723: End load test method

ISO 3724: Flow fatigue resistance method

ISO 3968: Pressure drop versus flow rate

ISO 16889: Multipass test.

For further information contact our Technical Dept.

MSE	Type	008	015	025	070	150	250	Type	CRH
	Filter media								
	CV = 25µ Paper	CV	CV	CV	CV	CV	CV	CV = 25µ Paper	
	MS = 60µ Steel wire mesh	MS	MS	MS	MS	MS	MS	MS = 60µ Steel wire mesh	
	MN = 90µ	MN	MN	MN	MN	MN	MN	MN = 90µ	
	Seals								
	1 = NBR Nitrile	1	1	1	1	1	1	1 = NBR Nitrile	
	2 = FKM Fluoroelastomer	2	2	2	2	2	2	2 = FKM Fluoroelastomer	
	Bypass type								
	S = Whitout	S	S	S	S	S	S		
	A = 30 kPa (0,3 bar)	A	A	A	A	A	A		
	Ports								
	B = BSP	B	B	B	B	B	-		
	N = NPT	N	N	N	N	N	-		
	S = SAE	S	S	S	S	S	-		
	F = SAE flange 3000 psi	-	-	F	F	F	F		
	Port size								
	3 = 1/2"	3	-	-	-	-	-		
	4 = 3/4"	-	4	-	-	-	-		
	5 = 1"	-	-	5	-	-	-		
	7 = 1" 1/2	-	-	-	7	-	-		
	9 = 2" 1/2	-	-	-	-	9	-		
	B = 3" 1/2	-	-	-	-	-	B		
	Indicators								
	08 = Port, plugged	08	08	08	08	08	08		
	11 = Vacuum gauge	11	11	11	11	11	11		
	91 = Vacuum switch	91	91	91	91	91	91		
XX	Accessories								
	XX = No accessory available	XX	XX	XX	XX	XX	XX		

DIMENSIONAL LAYOUT

(mm)

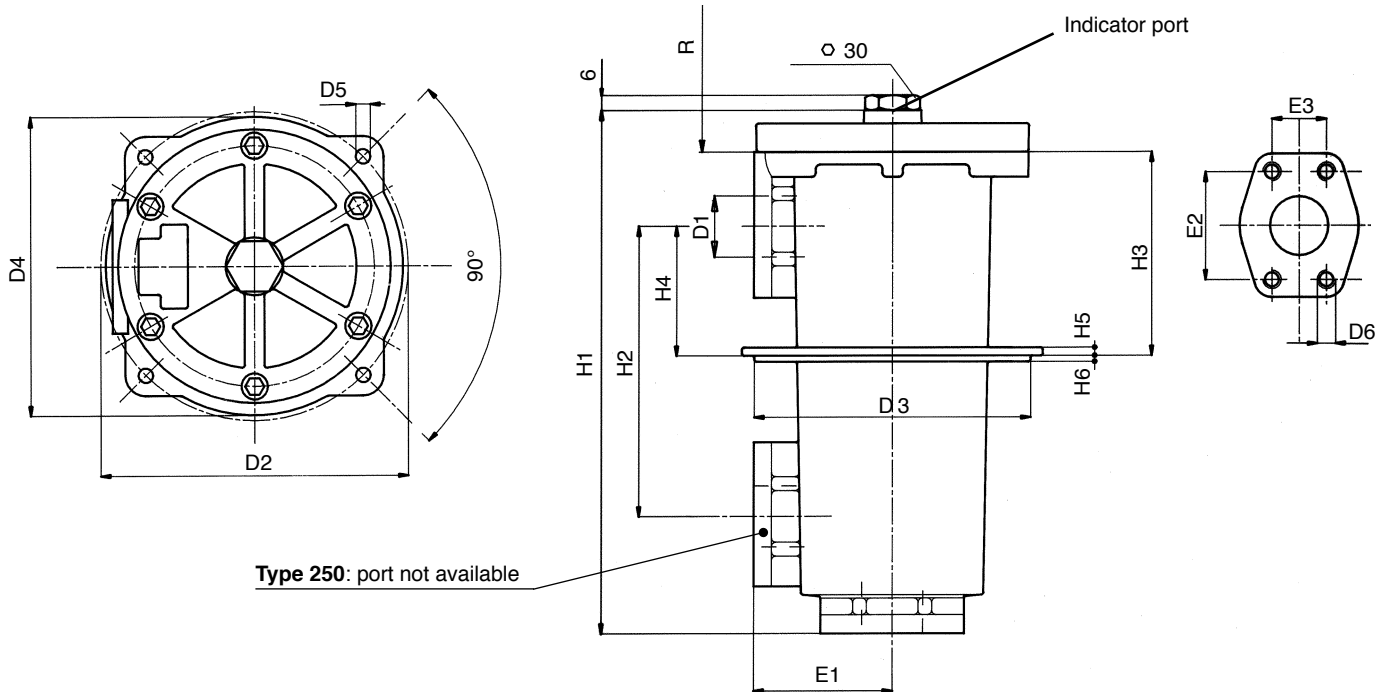

Type	D1	D2	D3	D4	D5	D6	E1	E2	E3	H1	H2	H3	H4	H5	H6	R	Weight Kg	
MSE 008...B	1/2" BSP	95	83,5	90	5,5	=	43	=	=	160	62,5	96	31,5	4	3	105	1,3	
MSE 008...N	1/2" NPT																	
MSE 008...S	SAE 8-3/4"-16UNF																	
MSE 015...B	3/4" BSP	138	121	128	6,5	=	57	=	=	191	105	100	52	6	3	110	2,6	
MSE 015...N	3/4" NPT																	
MSE 015...S	SAE 12-1 1/16"-12UN																	
MSE 025...B	1" BSP	154	135	147	6,5	M10	67	52,4	26,2	250	140	97	63	8	4	155	3,7	
MSE 025...N	1" NPT																	
MSE 025...S	SAE 16-1 5/16"-12UN																	
MSE 025...F	1" SAE 3000																	
MSE 070...B	1" 1/2 BSP	180	162	174	8,5	M12	82	70	35,7	323	177	155	82	8	4	240	6,5	
MSE 070...N	1" 1/2 NPT																	
MSE 070...S	SAE 24-1 7/8"-12UN																	
MSE 070...F	1" 1/2 SAE 3000																	
MSE 150...B	2" 1/2 BSP	275	237	254	10,5	M12	117,5	88,9	50,8	420	218	192	91	10	8	275	14,2	
MSE 150...N	2" 1/2 NPT																	
MSE 150...S	SAE 32-2 1/2"-12UN																	
MSE 150...F	2" 1/2 SAE 3000																	
MSE 250...F	3" 1/2 SAE 3000	275	237	300	14,5	M16	178	120,7	69,9	673	=	248	130	10	5	525	49,0	

CLOGGING INDICATORS

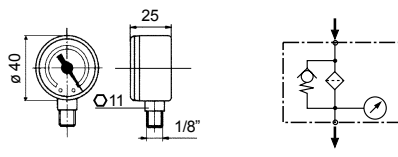
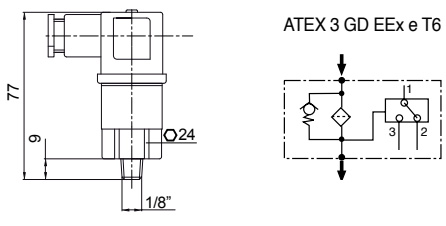
NBR	FKM	Vacuum gauge	
11	-	Scale 0 ÷ 100 kPa (1 bar)	
NBR	FKM	Pressure switch	
91	-	Setting 20 kPa (0,2 bar)	
SPDT, C.C. 30V: > max resistive or inductive load 3A - 1A respectively C.A. 125 or 250V: > max resistive or inductive load 3A - 0,5A respectively Protection IP65 - Connector DIN 43650			

FLOW RATES

(l/min)

$\Delta p = 5 \text{ kPa (0,05 bar)}$

Type	Filter Media		
	CV	MN	MS
MSE 008	28	40	36
MSE 015	34	80	72
MSE 025	55	120	108
MSE 070	120	330	300
MSE 150	170	650	580
MSE 250	250	850	770

The reference fluid has a kinematic viscosity of 30 cSt and a density of 0,86 Kg/dm³.
 For different oil viscosity please contact our Sales Department for further information.

FILTER AREA

(cm²)

Type	Filter Media			
	CD	CV	MN	MS
CRH 008	380	380	325	325
CRH 015	990	990	520	520
CRH 025	1600	1600	800	800
CRH 070	4280	4280	2330	2330
CRH 150	8350	8350	4065	4065
CRH 250	17600	17600	10000	10000